

- 1 A skier walks from the bottom of a ski slope to the top and gains 10 000 J of gravitational potential energy.

She skis down the slope. At the bottom of the slope, her kinetic energy is 2000 J.

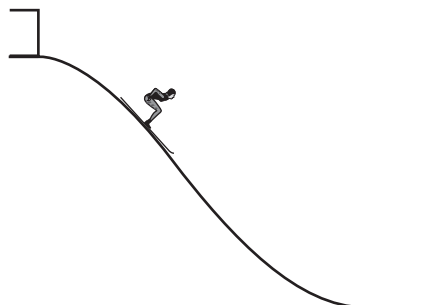

How much energy is dissipated in overcoming friction and air resistance as the skier moves down the slope?

- A** 2000 J **B** 8000 J **C** 10 000 J **D** 12 000 J

- 2 A coal-fired power station generates electricity. Coal is burnt and the energy released is used to boil water. The steam from the water makes the generator move and this produces electricity.

Which words are used to describe the energy stored in the coal and the energy of the moving generator?

	coal	generator
A	chemical	hydroelectric
B	chemical	kinetic
C	geothermal	hydroelectric
D	geothermal	kinetic

- 3 Four different children run up the same set of stairs.

For which child is the useful power to climb the stairs the greatest?

	mass of child / kg	time taken / s
A	40	15
B	50	25
C	60	25
D	70	15

- 4 Which energy source is one that is used to boil water to make steam in power stations?
- A energy from tides
 - B energy from waves
 - C hydroelectric energy
 - D nuclear energy

- 5 In a factory, two men X and Y try to move identical heavy boxes P and Q.

Man X tries to push box P along the floor. The box does not move because an object is in the way.

Man Y lifts box Q from the floor onto a shelf.

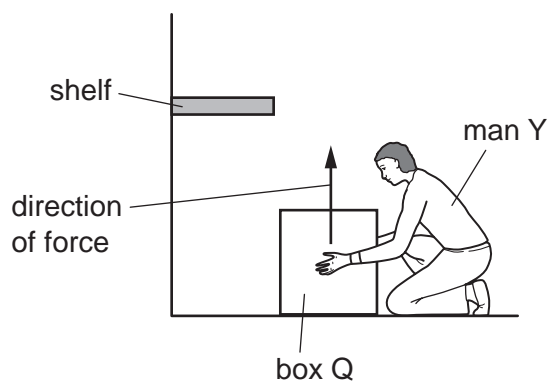
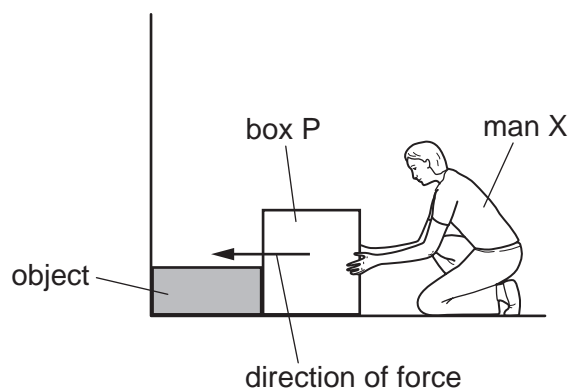

Which man does the most work on the box, and which box gains the most energy?

	man doing most work	box gaining most energy
A	X	P
B	X	Q
C	Y	P
D	Y	Q

- 6 Which energy source is renewable and reliably available at all times?
- A coal
 - B geothermal
 - C nuclear
 - D wind

- 7 Two workers are stacking cans on to a shelf in a shop. The workers lift the same number of identical cans on to the same shelf from the same level.

Worker P takes 3.0 minutes to lift the cans. Worker Q takes 4.0 minutes to lift the cans.

Which statement about the workers is correct?

- A Worker P develops less useful power than worker Q.
- B Worker P develops more useful power than worker Q.
- C Worker P does less useful work than worker Q.
- D Worker P does more useful work than worker Q.

- 8 Which quantities are measured in the same unit?

- A energy, power and work
- B energy and power, but not work
- C energy and work, but not power
- D power and work, but not energy

- 9 A person in a factory has to lift a box on to a shelf.

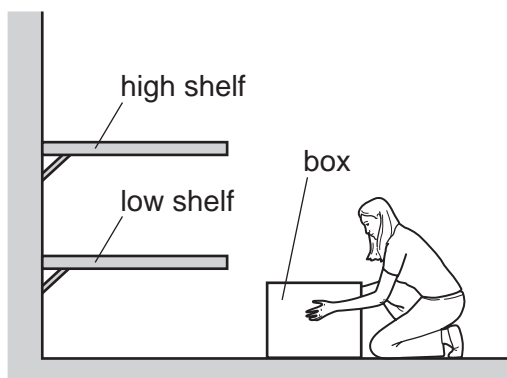

Which action involves the person doing the **least** amount of work?

- A lifting the box quickly to the high shelf
- B lifting the box slowly to the high shelf
- C lifting the box to the low shelf first then lifting it to the high shelf
- D lifting the box to the low shelf instead of to the high shelf

10 Which is a non-renewable energy resource?

- A coal
- B solar
- C tides
- D wind

11 A ball is dropped on to a hard surface and bounces. It does not bounce all the way back to where it started, and so has not regained all of its original gravitational potential energy.

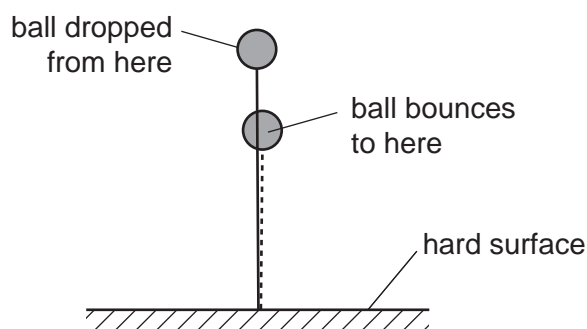

Which statement accounts for the loss of gravitational potential energy?

- A Energy was destroyed as the ball hit the ground.
- B Energy was destroyed as the ball travelled through the air.
- C The chemical energy and elastic energy of the ball have increased.
- D The internal (heat) energy of the ball and its surroundings has increased.

12 Which energy resource is used to boil water to generate electricity?

- A hydroelectric
- B nuclear fission
- C tides
- D waves

- 13 Two farmers use an electrically powered elevator to lift bales of hay. All the bales of hay have the same mass.

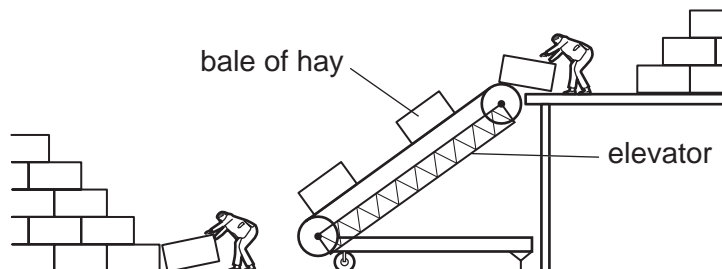

As sunset approaches, they increase the speed of the elevator so that more bales are lifted up in a given time.

How does this affect the work done in lifting each bale and the useful output power of the elevator?

	work done in lifting each bale	useful output power of the elevator
A	increases	decreases
B	increases	increases
C	no change	decreases
D	no change	increases

- 14 A student measures the length of a spring. She then hangs different weights from the spring. She measures the length of the spring for each different weight.

The table shows her results.

weight / N	length / mm
0	520
1.0	524
2.0	528
3.0	533
4.0	537
5.0	540

What is the extension of the spring when the weight hung from it is 3.0 N?

- A** 4 mm **B** 5 mm **C** 12 mm **D** 13 mm

15 Which energy resource is used to generate electricity without using any moving parts?

- A geothermal
- B hydroelectric
- C nuclear
- D solar

16 Which source of energy involves the splitting of heavy atoms?

- A chemical energy
- B geothermal energy
- C hydroelectric energy
- D nuclear energy

17 A cyclist travels down a hill from rest at point X, without pedalling.

The cyclist applies his brakes and the cycle stops at point Y.

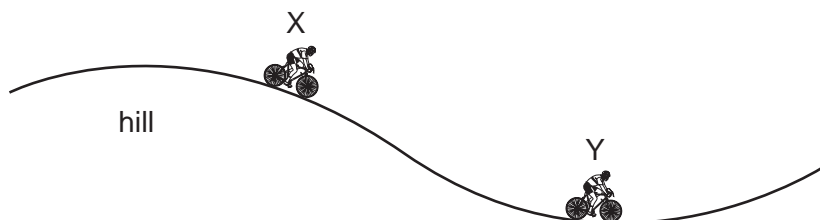

Which energy changes have taken place between X and Y?

- A gravitational potential → kinetic → thermal (heat)
- B gravitational potential → thermal (heat) → kinetic
- C kinetic → gravitational potential → thermal (heat)
- D kinetic → thermal (heat) → gravitational potential

- 18 To calculate the power produced by a force, the size of the force must be known.
 What else needs to be known to calculate the power?

	the distance the force moves the object	the time for which the force acts on the object
A	✓	✓
B	✓	x
C	x	✓
D	x	x

key
 ✓ = needed
 x = not needed

- 19 Which form of energy is used to generate electrical energy in a tidal power station?
- A** chemical energy
 - B** gravitational energy
 - C** internal energy (thermal energy)
 - D** nuclear energy
- 20 Four different model steam engines each lift a 1.0 kg object from the **same** laboratory floor to the **same** laboratory bench. Each engine takes a different time to lift the object.

How does the most powerful engine compare with the other engines?

	speed of lifting object onto bench	useful work done
A	faster	more than other engines
B	faster	same as other engines
C	slower	less than other engines
D	slower	same as other engines

21 What needs to be known to calculate the work done by a force acting on an object?

	the size of the force	the distance the force moves the object	the time for which the force acts
A	✓	✓	✓
B	✓	✓	x
C	✓	x	✓
D	✓	x	x

key

✓ = needed

x = not needed

22 Electrical energy may be obtained from nuclear fission.

In which order is the energy transferred in this process?

- A** nuclear fuel → generator → reactor and boiler → turbines
- B** nuclear fuel → generator → turbines → reactor and boiler
- C** nuclear fuel → reactor and boiler → generator → turbines
- D** nuclear fuel → reactor and boiler → turbines → generator

23 A car is stationary at the top of a hill with the engine switched off. The brakes are released and the car rolls down the hill.

At which labelled point does the car have the greatest kinetic energy? Ignore friction.

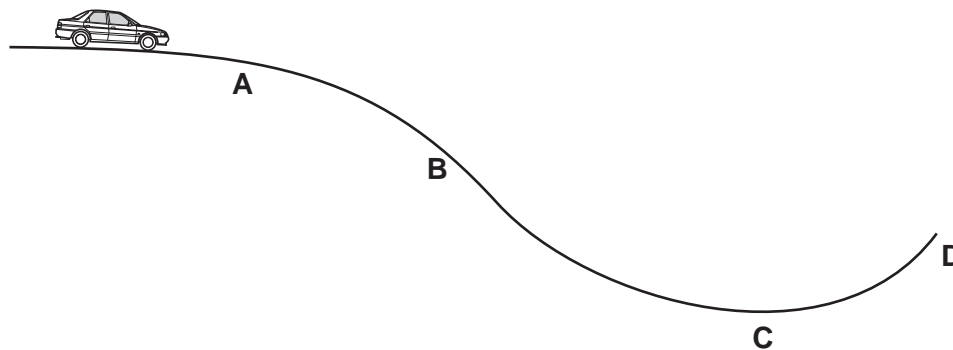

24 Which row gives the energy change in a battery and the energy change in a solar cell?

	battery	solar cell
A	chemical to electrical	electrical to light
B	chemical to electrical	light to electrical
C	electrical to chemical	electrical to light
D	electrical to chemical	light to electrical

25 A helicopter takes off from the ground and rises vertically. It then hovers at a constant height above the ground.

Which sequence of energy changes takes place during the gain in height?

- A** chemical → gravitational potential → kinetic
- B** chemical → kinetic → gravitational potential
- C** gravitational potential → chemical → kinetic
- D** kinetic → chemical → gravitational potential

26 Four people of equal weight on a beach use different routes to get to the top of a sea wall.

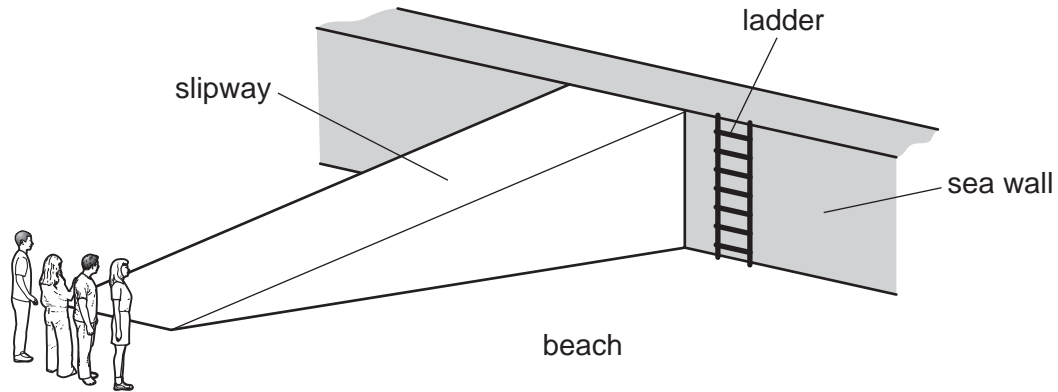

Which person produces the greatest average power?

person		time taken /s
A	runs across the beach, then climbs the ladder	8
B	walks across the beach, then climbs the ladder	16
C	runs up the slipway	5
D	walks up the slipway	10

27 Which energy transfer takes place when a matchstick burns?

- A** chemical to thermal
- B** chemical to nuclear
- C** nuclear to chemical
- D** thermal to chemical

28 Four cars are driven along a road.

The table shows the work done by the engine in each car and the time taken by each car.

Which engine produces the most power?

	work done by engine / J	time taken / s
A	50 000	20
B	50 000	40
C	100 000	20
D	100 000	40

29 In a hydroelectric power station, one form of energy is stored in a lake or reservoir. This energy is then transferred in stages to another useful form, which is the output.

Which row gives the name of the stored energy and the name of the output energy?

	stored energy	output energy
A	electrical	thermal (heat)
B	electrical	kinetic
C	gravitational	electrical
D	kinetic	electrical

30 A certain machine is very efficient.

What does this mean?

- A** It produces a large amount of power.
- B** It uses very little energy.
- C** It wastes very little energy.
- D** It works very quickly.

31 The list contains three energy resources P, Q and R.

- P geothermal energy from hot rocks
- Q nuclear fission in reactors
- R sunlight on solar panels

Which of these resources are renewable?

- A P and Q only
 - B P and R only
 - C Q and R only
 - D P, Q and R
- 32 Which movement will require the greatest amount of work to be done?
- A a force of 10 N moving an object a distance of 3.0 m
 - B a force of 10 N moving an object a distance of 5.0 m
 - C a force of 15 N moving an object a distance of 3.0 m
 - D a force of 15 N moving an object a distance of 5.0 m
- 33 When a bicycle lamp is switched on, what is the useful energy change **within the battery**?
- A chemical energy to electrical energy
 - B electrical energy to chemical energy
 - C electrical energy to light energy
 - D light energy to chemical energy

34 A student does some work by pulling a suitcase along a corridor.

She now pulls a second suitcase along the corridor.

Which row indicates that the student is now doing twice as much work?

	the force used to pull suitcase	the distance the suitcase is pulled
A	is doubled	is doubled
B	is doubled	is halved
C	stays the same	is doubled
D	stays the same	is halved

35 The diagram shows a hydroelectric system.

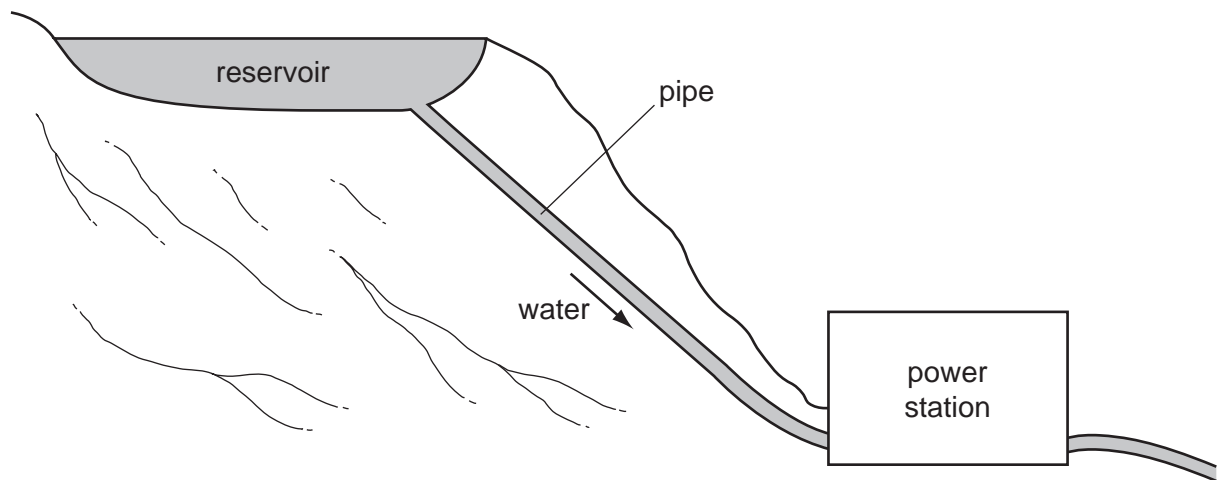

What are the main energy changes taking place?

- A** chemical energy → kinetic energy → electrical energy
- B** electrical energy → gravitational energy → kinetic energy
- C** gravitational energy → kinetic energy → electrical energy
- D** kinetic energy → electrical energy → gravitational energy

- 36 An escalator (moving stairs) and a lift (elevator) are both used to carry passengers from the same underground railway platform up to street level.

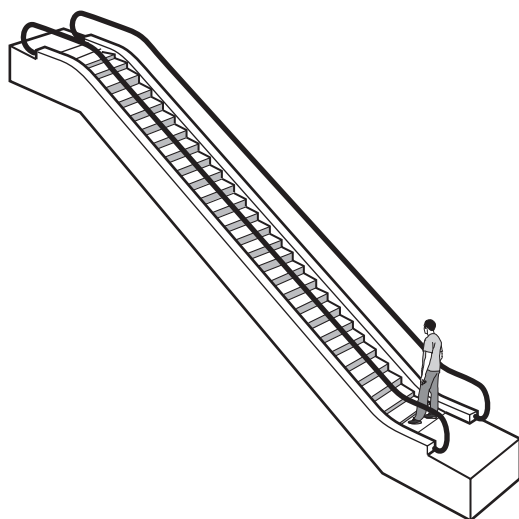

escalator

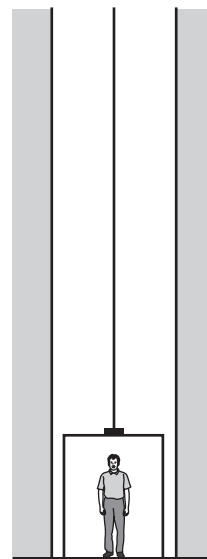

lift

The escalator takes 20 seconds to carry a man to street level. The useful work done is W . The useful power developed is P . The lift takes 30 seconds to carry the same man to street level.

How much useful work is done by the lift, and how much useful power is developed by the lift?

	useful work done by lift	useful power developed by lift
A	more than W	less than P
B	more than W	P
C	W	less than P
D	W	P

37 A car moves along a level road at constant speed. Work is done by the engine and power is developed by the engine.

Which pair of graphs shows how the work done and the power developed vary with time?

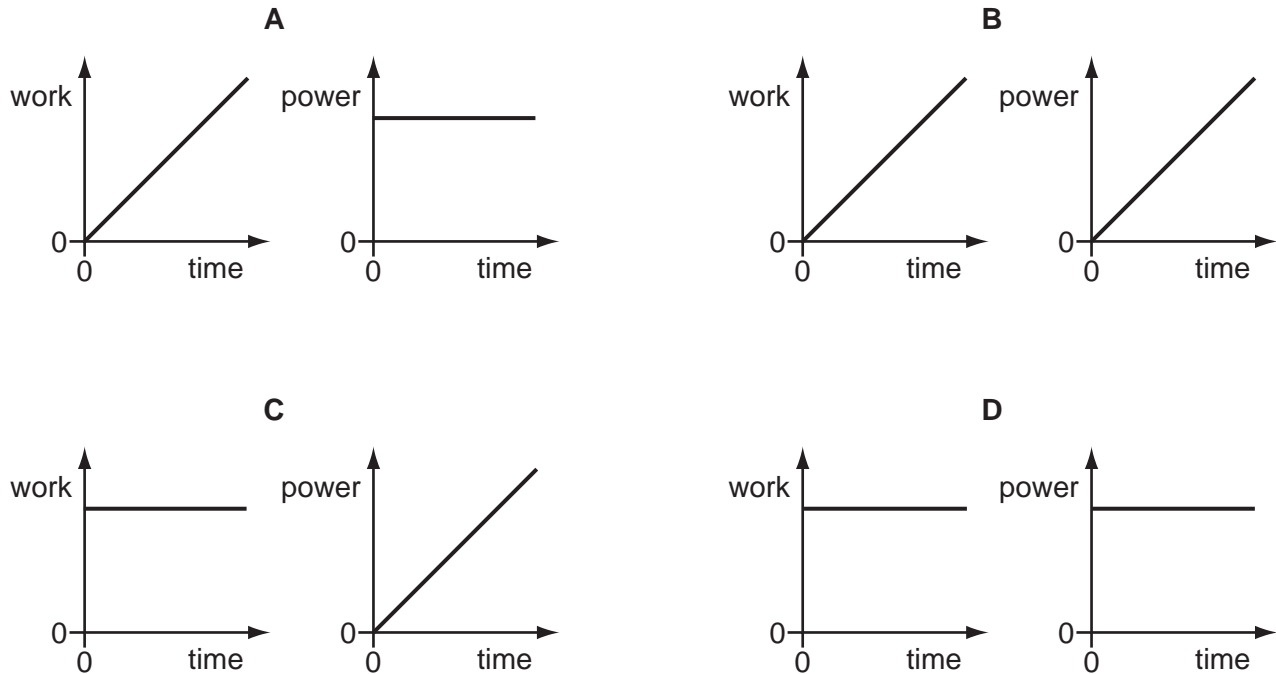

38 Some energy sources are reliably available at all times, and some are not.

Which row shows three sources all in their correct columns?

	available at all times	not available at all times
A	geothermal	nuclear fission, solar
B	geothermal, nuclear fission	solar
C	solar, nuclear fission	geothermal
D	solar	nuclear fission, geothermal

39 A woman in a factory has to lift a box on to a shelf.

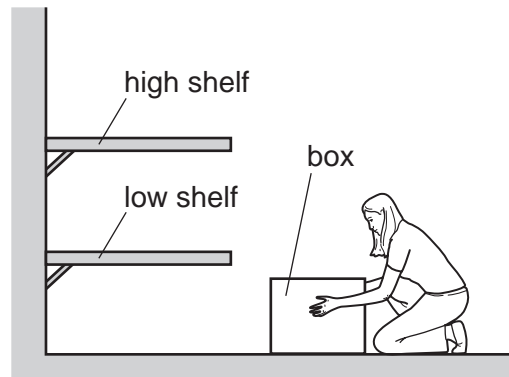

Which action involves the woman in doing the **least** amount of work?

- A lifting the box quickly to the high shelf
 - B lifting the box slowly to the high shelf
 - C lifting the box to the low shelf first then lifting it to the high shelf
 - D lifting the box to the low shelf instead of to the high shelf
- 40 An aeroplane is landing. As it descends towards the runway, its speed reduces.

What are the energy changes that take place during the descent?

- A kinetic + gravitational \rightarrow thermal (heat)
 - B kinetic \rightarrow gravitational + thermal (heat)
 - C kinetic + thermal (heat) \rightarrow gravitational
 - D thermal (heat) \rightarrow kinetic + gravitational
- 41 Energy from uranium is transferred to electrical energy in a nuclear power station.

What is the correct order of the stages of this process?

- A boiler \rightarrow generator \rightarrow reactor \rightarrow turbine
- B generator \rightarrow boiler \rightarrow turbine \rightarrow reactor
- C reactor \rightarrow boiler \rightarrow turbine \rightarrow generator
- D reactor \rightarrow turbine \rightarrow boiler \rightarrow generator

42 In which pair of energy sources are both sources renewable?

- A oil and coal
- B oil and tidal
- C tidal and geothermal
- D tidal and nuclear fission

43 An object on a thread is swinging between X and Z, as shown in the diagram. It is momentarily at rest at X and at Z.

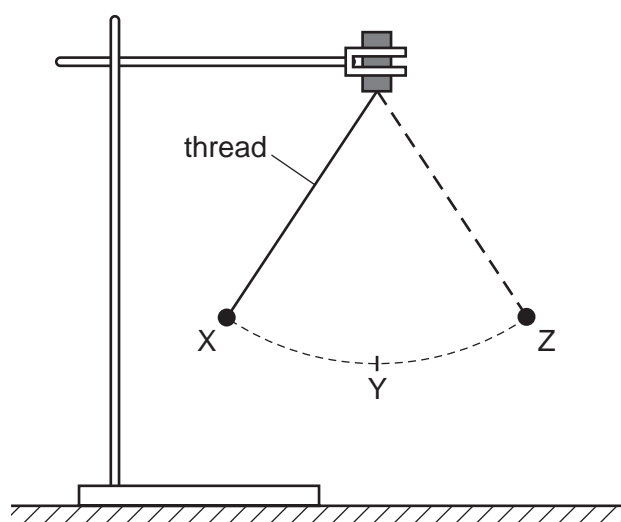

An incomplete word equation about the energy of the object is shown below.

$$\begin{array}{ccccccc} \text{gravitational potential energy} & = & \text{kinetic energy} & + & \text{..... energy} & + & \text{energy losses} \\ \text{at X} & & \text{at Y} & & \text{at Y} & & \end{array}$$

Which form of energy is needed to complete the word equation?

- A chemical
- B gravitational potential
- C internal
- D strain

44 Electricity can be obtained from different energy resources.

Which energy resource is used to obtain electricity without producing heat to boil water?

- A coal
- B gas
- C hydroelectric
- D nuclear

45 A ball is dropped on to a hard surface and bounces. It does not bounce all the way back to where it started, so it has less gravitational potential energy than when it started.

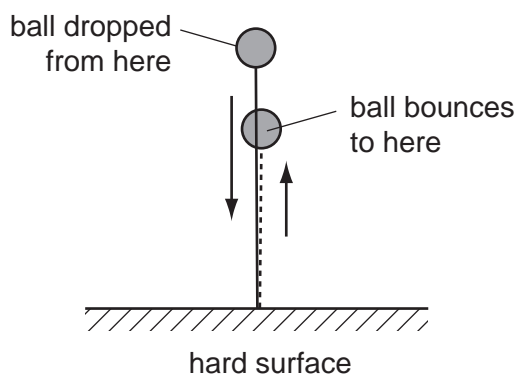

What happens to the 'lost' energy?

- A It is converted into chemical and strain energy.
- B It is converted into internal (heat) energy and sound.
- C It is destroyed as the ball rises upwards after hitting the ground.
- D It is destroyed when the ball hits the ground.

46 Which row gives an example of the stated form of energy?

	form of energy	example
A	gravitational	the energy due to the movement of a train along a level track
B	internal	the energy due to the flow of cathode rays in a cathode-ray tube
C	kinetic	the energy due to the position of a swimmer standing on a high diving board
D	strain	the energy due to the compression of springs in a car seat

47 Which energy resource is used to generate electricity by first boiling water?

- A** hydroelectric
- B** nuclear fission
- C** tides
- D** waves

48 Two farmers use an electrically powered elevator to lift bales of hay. All the bales of hay have the same mass.

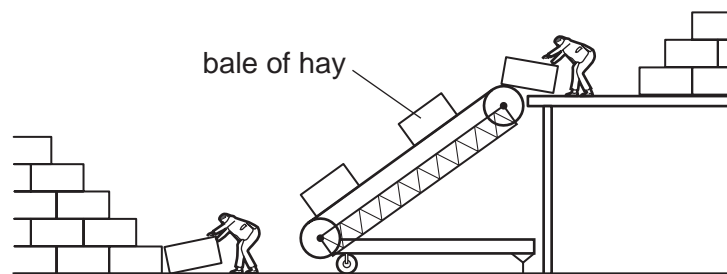

As sunset approaches, they increase the speed of the motor so that more bales are lifted up in a given time.

How does this affect the work done in lifting each bale and the useful output power of the motor?

	work done in lifting each bale	useful output power of the motor
A	increases	decreases
B	increases	increases
C	no change	decreases
D	no change	increases

49 A force F moves a load from the bottom of a slope to the top.

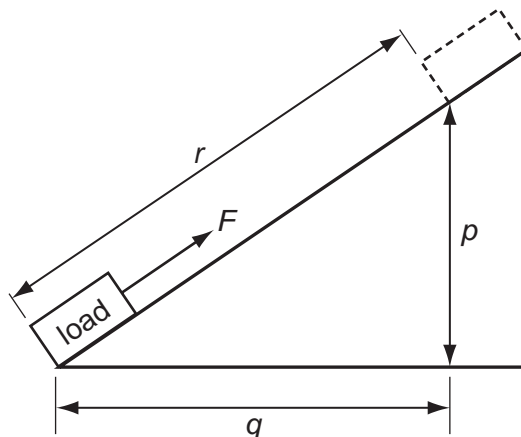

The work done by the force depends on the size of the force, and on a distance.

What is this distance?

- A** p **B** q **C** r **D** $p + q$

50 Energy is released in some nuclear reactions.

Which nuclear reaction takes place in a nuclear power station, and which nuclear reaction takes place in the Sun?

	nuclear power station	the Sun
A	fission	fission
B	fission	fusion
C	fusion	fission
D	fusion	fusion

51 A lorry of mass 4000 kg is travelling at a speed of 4.0 m/s.

A car has a mass of 1000 kg. The kinetic energy of the car is equal to the kinetic energy of the lorry.

What is the speed of the car?

- A** 2.0 m/s **B** 4.0 m/s **C** 8.0 m/s **D** 16.0 m/s

52 A force acts on an object and causes the object to move a certain distance, in the same direction as the force.

Which row represents a situation in which the largest amount of work is done on the object by the force?

	force/N	distance moved/m
A	2.0	40.0
B	10.0	2.0
C	20.0	6.0
D	100.0	1.0

53 A stone of mass m is held at rest in water. The stone is released and falls vertically a distance h . The stone reaches a speed v .

Some of the original energy of the stone is transferred to the water. As it falls, resistive forces cause the temperature of the water and stone to increase.

Which expression gives the work done against the resistive forces?

- A** $\frac{1}{2}mv^2$
B $mgh - \frac{1}{2}mv^2$
C mgh
D $mgh + \frac{1}{2}mv^2$

54 Which energy resource does **not** derive its energy from the Sun?

- A geothermal
- B hydroelectric
- C oil
- D waves

55 Some processes are more efficient than others.

Which expression gives the efficiency of a process?

- A $\frac{\text{total energy output}}{\text{total energy input}} \times 100\%$
- B $\frac{\text{useful energy output}}{\text{total energy input}} \times 100\%$
- C $\frac{\text{wasted energy output}}{\text{total energy input}} \times 100\%$
- D $\frac{\text{wasted energy output}}{\text{useful energy output}} \times 100\%$

56 Which energy resource does **not** derive its energy from the Sun?

- A hydroelectric
- B nuclear fission
- C waves
- D wind

57 The diagram shows the energy used by a modern lamp.

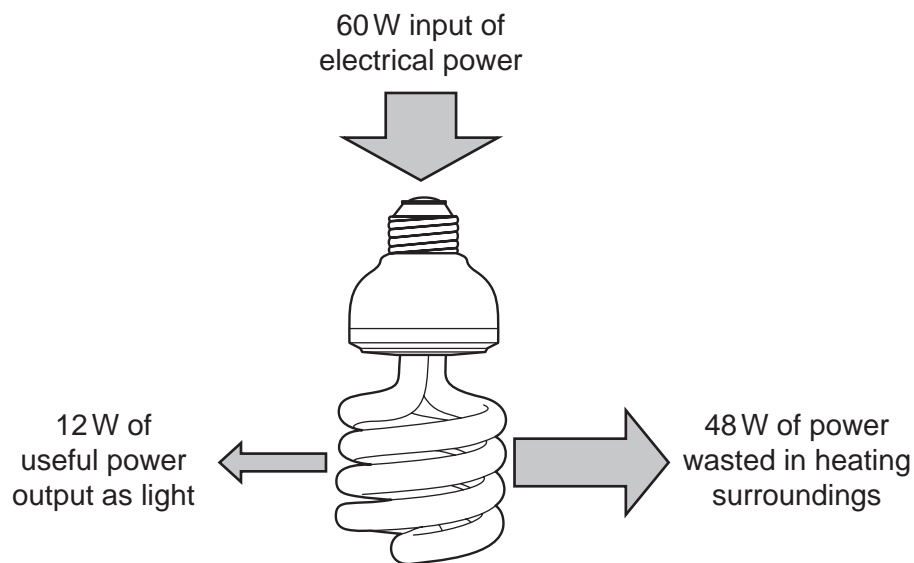

Which expression gives the efficiency of the lamp?

- A** $\frac{12}{60} \times 100\%$ **B** $\frac{12}{48} \times 100\%$ **C** $\frac{48}{60} \times 100\%$ **D** $\frac{48}{12} \times 100\%$

58 Three boxes each weigh 100N. A man lifts all the boxes together from the ground on to a shelf that is 1.5m above the ground. The man takes 2.0s to do this.

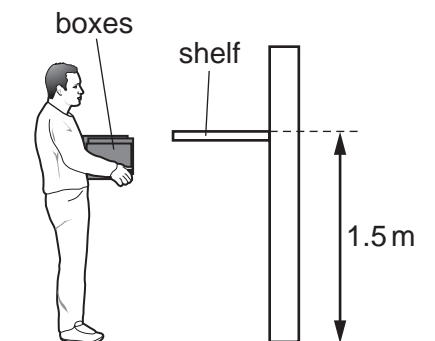

How much useful power does the man produce to lift the boxes?

- A** 75W **B** 225W **C** 300W **D** 900W

59 The table gives four energy sources and states whether the energy of the source is derived from the Sun.

Which row is correct?

	source of energy	derived from the Sun
A	geothermal	yes
B	oil	no
C	water held behind a dam	yes
D	wind	no

60 A weight-lifter raises a 2000 N weight through a vertical height of 2.0 m in 0.80 s.

What useful power does he develop in doing this?

- A** 800 W **B** 3200 W **C** 4000 W **D** 5000 W

61 A wind turbine generates 54 kW of useful power from an input of 180 kW of wind power.

Which calculation gives the percentage efficiency of the turbine?

- A** $\frac{54000}{180000 \times 100} \%$
- B** $\frac{180000}{54000 \times 100} \%$
- C** $\frac{54000 \times 100}{180000} \%$
- D** $\frac{180000 \times 100}{54000} \%$

62 A car has a mass of 1000 kg and a momentum of 12 000 kg m/s.

What is its kinetic energy?

- A 6 kJ
- B 12 kJ
- C 72 kJ
- D 144 kJ

63 A ball is dropped on to a hard surface and bounces. It does not bounce all the way back to where it started, and so has not regained all of its original gravitational potential energy.

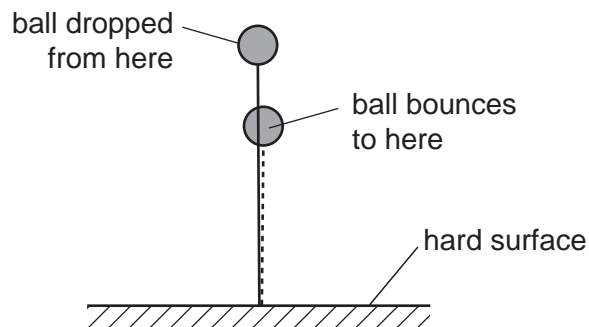

Which statement accounts for the loss of gravitational potential energy?

- A Energy was destroyed as the ball hit the ground.
 - B Energy was destroyed as the ball travelled through the air.
 - C The chemical energy and elastic energy of the ball have increased.
 - D The internal (heat) energy of the ball and its surroundings has increased.
- 64 The Sun is the original source of energy for many of our energy resources.

Which energy resource **does not** originate from the Sun?

- A geothermal
- B hydroelectric
- C waves
- D wind