

- 1 A student wishes to determine the density of an irregularly-shaped stone.

First he finds the mass of the stone. Next he lowers the stone into a measuring cylinder containing water.

The diagrams show the measuring cylinder before and after the stone is lowered into it.

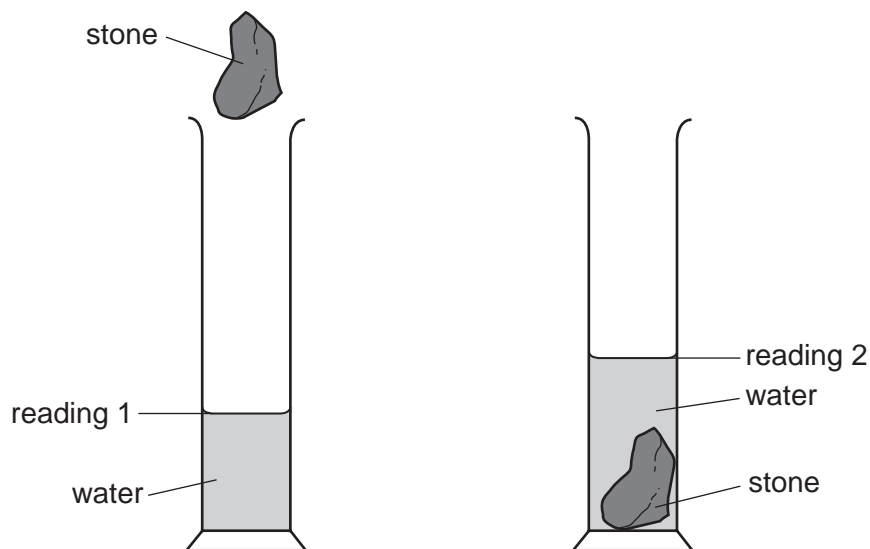

How should the student calculate the density of the stone?

- A mass of stone \times reading 2
 - B mass of stone \times (reading 2 – reading 1)
 - C mass of stone \div reading 2
 - D mass of stone \div (reading 2 – reading 1)
- 2 The diagrams show the dimensions and masses of four regular solid objects. The objects are made from different metals.

Which metal has the greatest density?

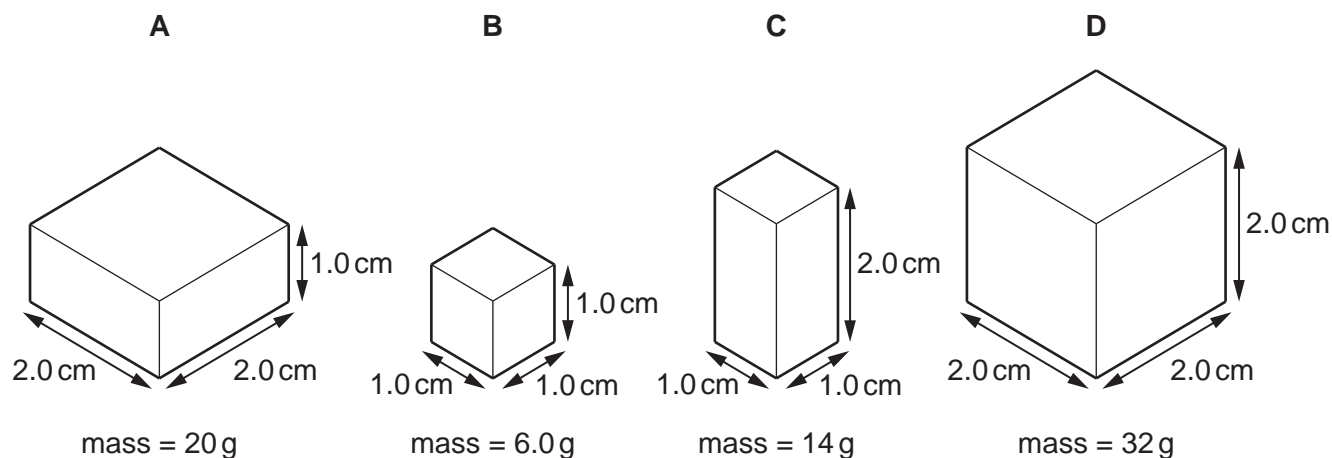

3 Diagram 1 shows a measuring cylinder containing water.

Diagram 2 shows the same measuring cylinder and water after 10 identical solid glass spheres have been added.

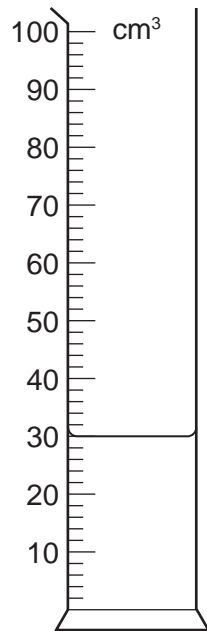

diagram 1

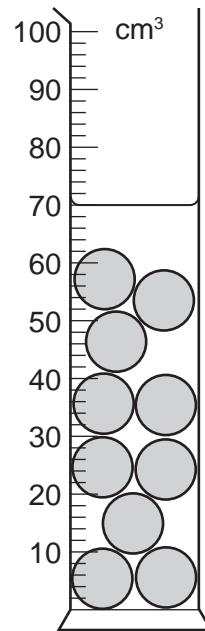

diagram 2

The mass of one of the spheres is 10 g.

What is the density of the glass from which the spheres are made?

- A** 0.25g/cm^3 **B** 0.40g/cm^3 **C** 2.5g/cm^3 **D** 4.0g/cm^3

4 The diagram shows a cuboid block made from a metal of density 2.5g/cm^3 .

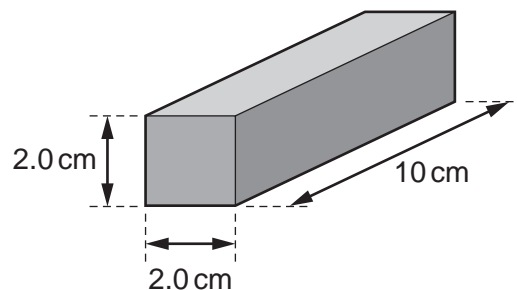

What is the mass of the block?

- A** 8.0 g **B** 16 g **C** 50 g **D** 100 g

5 The diagram shows an experiment to find the density of a liquid.

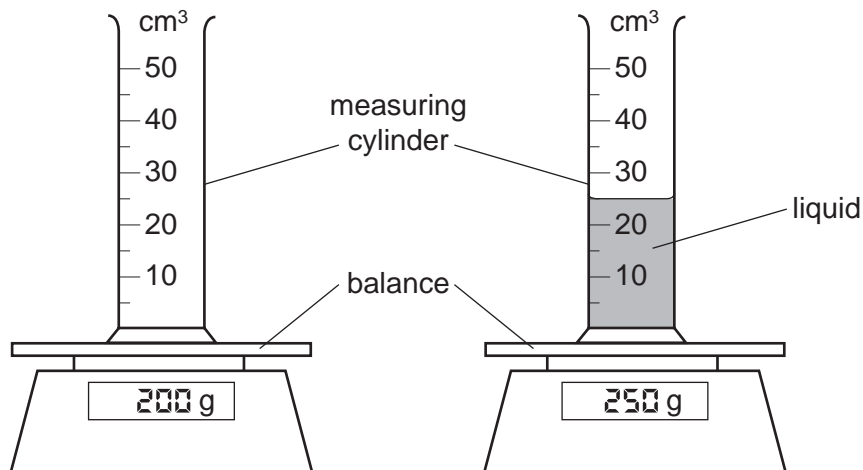

What is the density of the liquid?

- A** 0.5g/cm³ **B** 2.0g/cm³ **C** 8.0g/cm³ **D** 10.0g/cm³

6 Diagram 1 shows a piece of foam rubber that contains many pockets of air. Diagram 2 shows the same piece of foam rubber after it has been compressed so that its volume decreases.

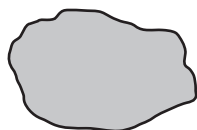

diagram 1
(before compression)

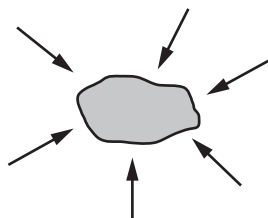
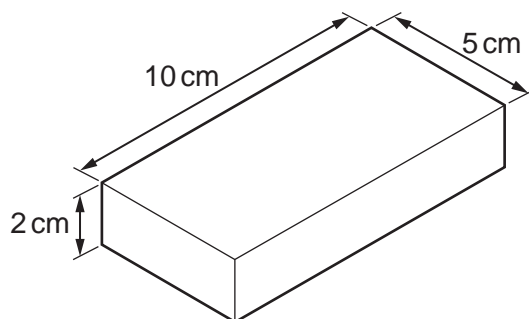

diagram 2
(after compression)

What happens to the mass and to the weight of the foam rubber when it is compressed?

	mass	weight
A	increases	increases
B	increases	no change
C	no change	increases
D	no change	no change

- 7 A metal block has the dimensions shown. Its mass is 1000g.



What is the density of the metal?

- A** $\left(\frac{5 \times 10}{1000 \times 2}\right) \text{g/cm}^3$
- B** $\left(\frac{2 \times 5 \times 10}{1000}\right) \text{g/cm}^3$
- C** $\left(\frac{1000 \times 2}{5 \times 10}\right) \text{g/cm}^3$
- D** $\left(\frac{1000}{2 \times 5 \times 10}\right) \text{g/cm}^3$
- 8 Which substance in the table has the lowest density?

	substance	/g	volum /cm ³
A	nylon		1.0
B	cotton		1.0
C	olive oil	1.8	2.0
D	water		2.0

- 9 A student wishes to determine the density of the solid block shown.

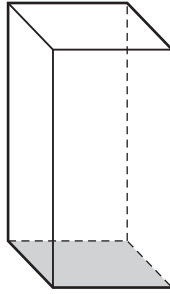

Which quantities must be known?

- A the area of the shaded face and the volume of the block
 - B the area of the shaded face and the weight of the block
 - C the mass of the block and the height of the block
 - D the mass of the block and the volume of the block
- 10 Two cylinders are made of the same metal. Both cylinders have the same cross-sectional area but one is longer than the other.



cylinder 1



cylinder 2

Which quantity is the same for both cylinders?

- A density
 - B mass
 - C resistance
 - D volume
- 11 The mass of a piece of metal is 1200 g.
- A measuring cylinder contains 150 cm^3 of water.
- The piece of metal is put into the measuring cylinder. The water level rises to 250 cm^3 and covers the metal.

What is the density of the metal?

- A 3.0 g/cm^3
- B 4.8 g/cm^3
- C 8.0 g/cm^3
- D 12.0 g/cm^3

12 A person measures the length, width, height and mass of a metal block with rectangular sides.

Which of these measurements must be used in order to calculate the density of the metal?

- A mass only
- B height and mass only
- C length, width and height only
- D length, width, height and mass

13 A liquid has a volume of 100 cm^3 and a mass of 85 g.

The density of water is 1.0 g/cm^3 .

How does the density of the liquid compare with the density of water?

- A Its density is higher than that of water.
- B Its density is lower than that of water.
- C Its density is the same as that of water.
- D It is impossible to say with only this data.

14 The table gives the volumes and masses of four objects.

Which object has the greatest density?

	mass/g	volum / cm^3
A	5.4	
B	13	3
C	15	6
D	18	5

- 15 The diagram shows the dimensions of a rectangular block of metal of mass m .

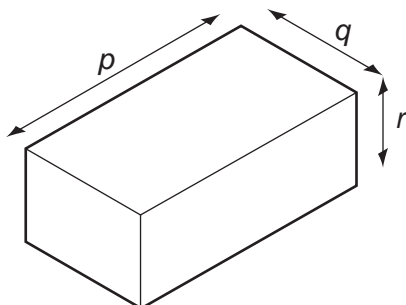

Which expression is used to calculate the density of the metal?

- A** $m \times p \times q$
- B** $m \times p \times q \times r$
- C** $\frac{m}{(p \times q)}$
- D** $\frac{m}{(p \times q \times r)}$

16 Diagram 1 shows an empty measuring cylinder on a balance.

Diagram 2 shows the same measuring cylinder on the balance, but it now contains a liquid.

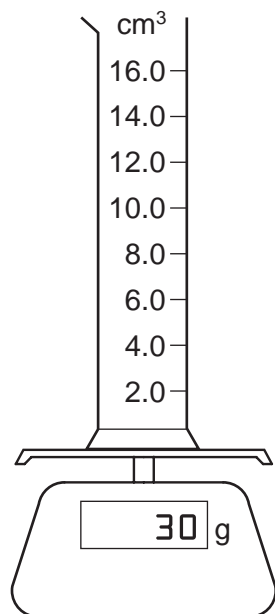

diagram 1

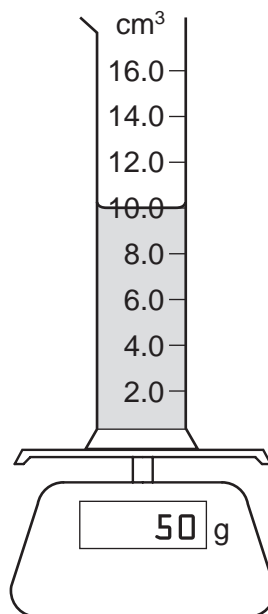
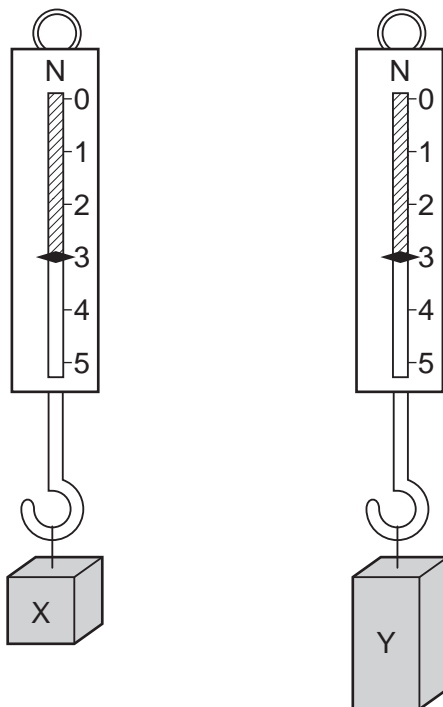

diagram 2

What is the density of the liquid?

- A** 0.2g/cm^3 **B** 0.5g/cm^3 **C** 2.0g/cm^3 **D** 5.0g/cm^3

17 Two blocks of metal X and Y hang from spring balances, as shown in the diagrams.



What does the diagram show about X and Y?

- A** They have the same mass and the same volume but different weights.
- B** They have the same mass and the same weight but different volumes.
- C** They have the same mass, the same volume and the same weight.
- D** They have the same weight and the same volume but different masses.

18 A measuring cylinder has a mass of 120g when empty.

When it contains 50 cm³ of a liquid, the total mass of the measuring cylinder and the liquid is 160g.

What is the density of the liquid?

- A $\frac{40}{50} \text{ g/cm}^3$
- B $\frac{50}{40} \text{ g/cm}^3$
- C $\frac{120}{50} \text{ g/cm}^3$
- D $\frac{160}{50} \text{ g/cm}^3$

19 A measuring cylinder containing liquid is placed on a top-pan balance. The apparatus is left overnight and some of the liquid evaporates. The diagrams show the readings.

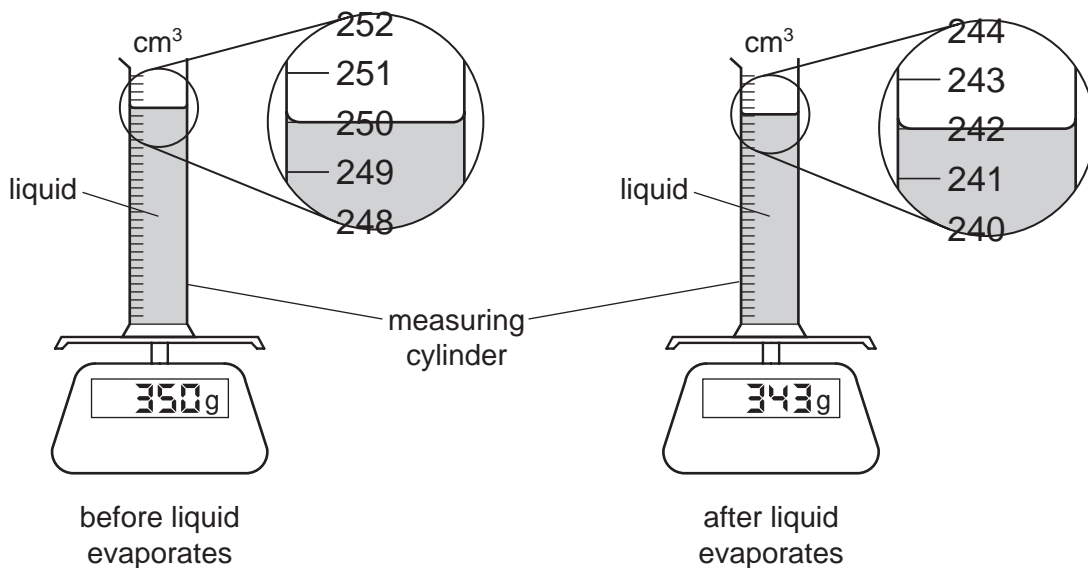

What is the density of the liquid?

- A 0.875g/cm³
- B 1.14g/cm³
- C 1.40g/cm³
- D 1.42g/cm³

- 20 Four rectangular blocks, P, Q, R and S are shown. Each block is labelled with its size and its mass.

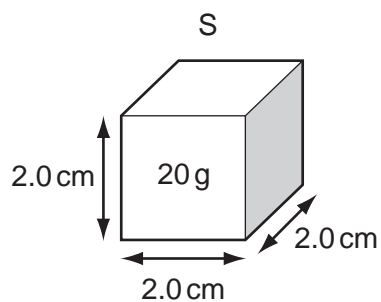
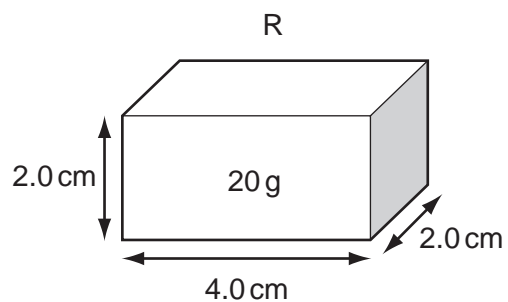
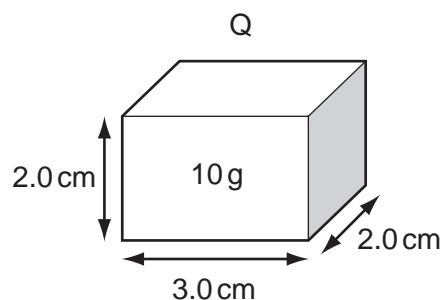
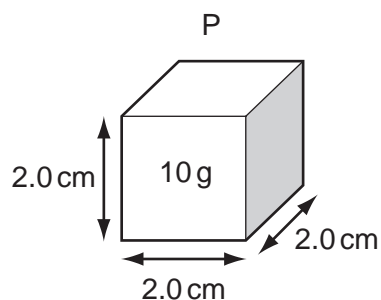

Which two blocks have the same density?

- A** P and Q **B** P and R **C** Q and R **D** R and S

- 21 A student is given four different objects and a metre rule. Each object has a known mass. She is asked to determine the densities of the materials from which the four objects are made.

The objects are a copper cylinder, a glass cube, a steel spanner and a stone tile.



copper

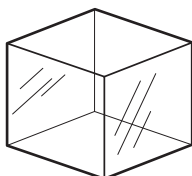

glass

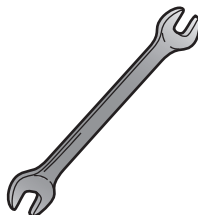

steel

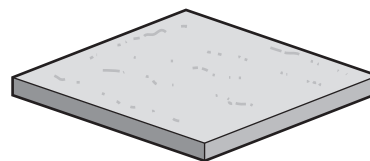

stone

Using only the metre rule, she is able to find the densities of only three of the four materials.

Which three materials are these?

- A** copper, glass and steel
 - B** copper, glass and stone
 - C** copper, steel and stone
 - D** glass, steel and stone
- 22 A stone has a volume of 0.50 cm^3 and a mass of 2.0 g .

What is the density of the stone?

- A** 0.25 g/cm^3
- B** 1.5 g/cm^3
- C** 2.5 g/cm^3
- D** 4.0 g/cm^3

23 A cube of side 2.0 cm is placed on a balance.

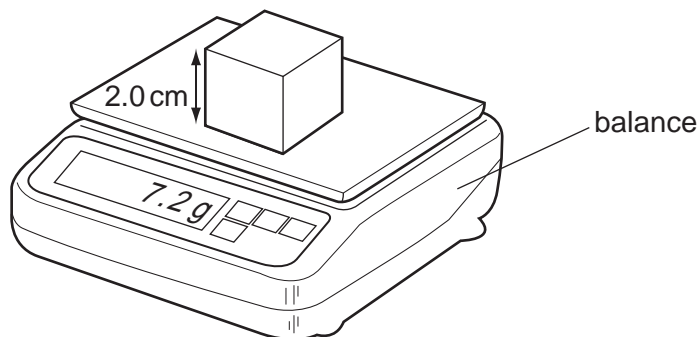

What is the density of the cube?

- A** 0.90g/cm³ **B** 1.2g/cm³ **C** 1.8g/cm³ **D** 3.6g/cm³

24 The diagrams show four blocks with the same mass.

Which block is made from the least dense material?

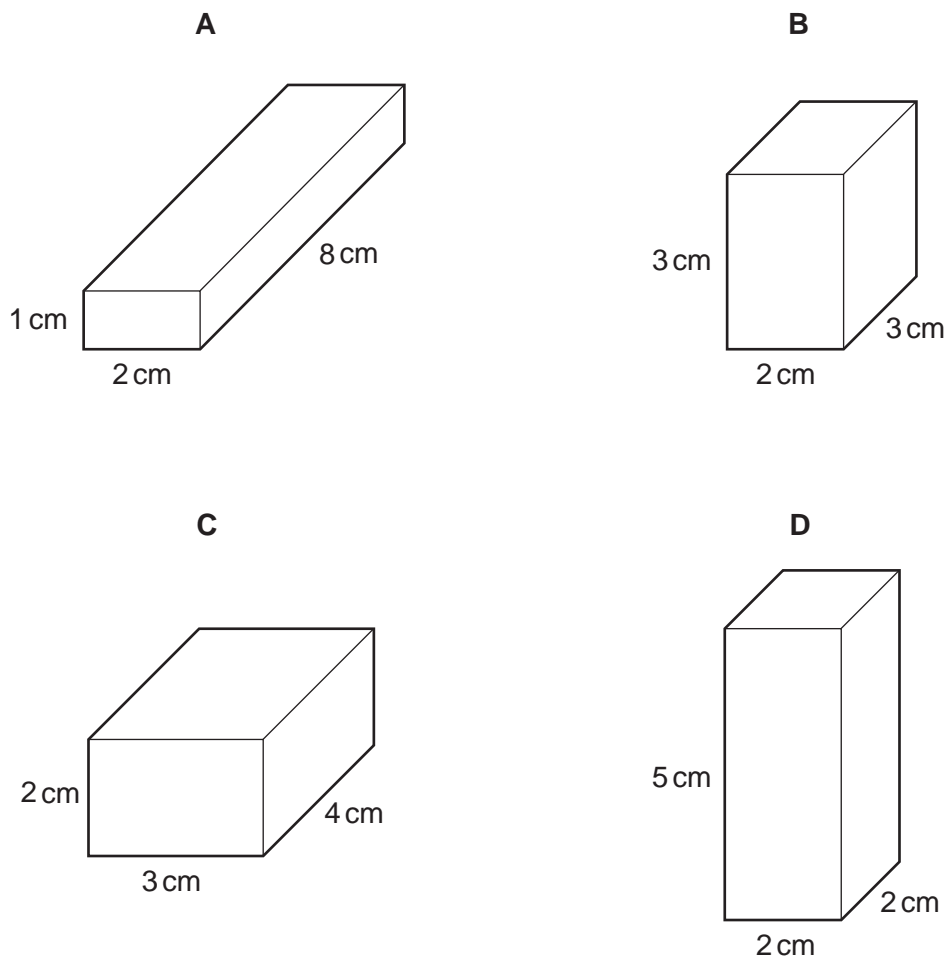

25 A student is told to measure the density of a liquid and also of a large cube of metal.
Which pieces of equipment are sufficient to be able to take the measurements needed?

- A balance, measuring cylinder and ruler
- B balance and thermometer
- C measuring cylinder and ruler
- D measuring cylinder, ruler and thermometer

26 The diagram shows a cuboid block made from a metal of density 2.5 g/cm^3 .

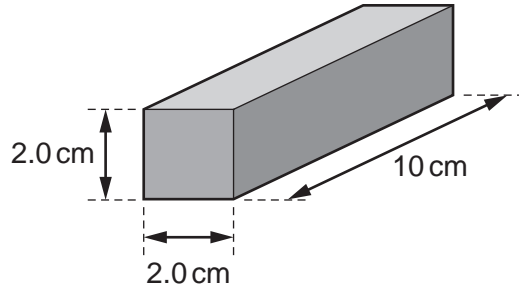

What is the mass of the block?

- A 8.0g
- B 16g
- C 50g
- D 100g

27 The diagram shows an experiment to find the density of a liquid.

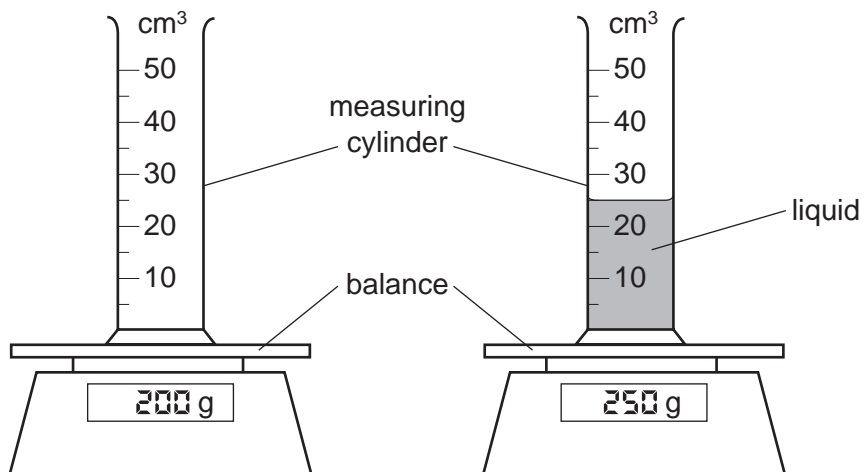

What is the density of the liquid?

- A** 0.5g/cm^3 **B** 2.0g/cm^3 **C** 8.0g/cm^3 **D** 10.0g/cm^3